

COAXIAL SURGE PROTECTOR DEVICE, High-power/low-IM GDT hybrid technology

3409.31.0003

Properties

- DC continuity for remote powering
- RF peak power not limited by gas discharge tube
- Excellent low PIM performance; Ideal for multicarrier systems
- Availability for application bands between 380 MHz and 18 GHz
- Gas discharge tube installed
- Mounting screw set included
- AISG compliant for 2.176 MHz carrier

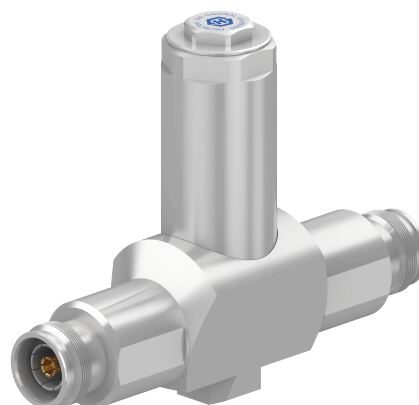

Product configuration

Main path connectors	Port 1: unprotected, 4.3-10 jack (female) Port 2: protected, 4.3-10 jack (female)
Mounting and grounding	M8 (screw), brk (bracket)
EMP can be install reversed	YES

Interface and material data

Housing material / plating	Brass / SUCOPLATE (R) Plating
Center contact, material / plating	Port 1: Bronze / Silver Plating Port 2: Bronze / Silver Plating

Electrical data

Frequency frame	690 MHz to 2700 MHz
Return loss typical	≥ 24 dB
Insertion loss typical	≤ 0.15 dB
CW power frame	≤ 500 W
Peak power frame	≤ 2000 W
PIM 3rd order	-160 dBc typ.
AISG frequency	10 MHz
AISG return loss	18 dB
AISG insertion loss	0.1 dB
Residual pulse energy (typ.)	350 μJ (test pulse 4 kV 1.2/50 μs; 2 kA 8/20 μs)

COAXIAL SURGE PROTECTOR DEVICE, High-power/low-IM GDT hybrid technology

3409.31.0003

Electrical data	
Surge current handling capability	30 kA single, 20 kA multiple (test pulse 8/20 µs)

Electrical remarks	
DC supply voltage	48 V
DC current	13 A
Gas tube	Yes DC, GDT included, replaceable, 9071.99.0548 (90 V)

Mechanical data	
Weight	510 g
Mating cycles	500

Environmental data	
Operation temperature	-40 °C ... 85 °C
Storage temperature	-40 °C ... 85 °C
Ingress protection (IP Rating)	Mated / IP67, according to IEC 60529
Thermal shock according	MIL-STD-202, Method 107, Cond. B
Vibration according	MIL-STD-202, Method 204, Cond. A
Moisture resistance according	MIL-STD-202, Method 106

Compliance			
Item number	Directive / Regulation	Rating	Exemptions / Details
85115346	RoHS 2011/65/EU and (EU) 2015/863	Compliant with exemption	6c
	REACH 1907/2006 Article 33 SVHC	Contains one or more SVHC >0,1%	CAS: 7439-92-1 Lead

Ordering Information Table	
Item number	Item description
85115346	3409.31.0003

HUBER+SUHNER is certified by ISO 9001, ISO 14001, ISO 45001, IATF 16949, AS/EN 9100 and ISO/TS 22163-IRIS. Waiver: Facts and figures herein are for information only and do not represent any warranty of any kind.
DOCUMENT PIM-P51434 / Date of publication: 01.03.2025 / uncontrolled copy

HUBER+SUHNER EMP protectors

General mounting and grounding instructions for lightning EMP protectors



Series 3400, 3401, 3402, 3403, 3404, 3405, 3406, 3407, 3408, 3409, 3410



HUBER+SUHNER EMP protectors provide reliable protection against dangerous surge signals on coaxial lines. This includes all kinds of interference, e.g. resistive, magnetic field and electric field coupling, caused by lightning strikes, switching and other natural or man made electrical effects.

Integration of protective devices

The international standard IEC 62305 describes protection against lightning. According to IEC 62305 the protective device integration is based on the lightning protection zone (LPZ) concept with bonding and shielding.

1. Preferred installation

The protection zone principle favours the feed-through installation in a well conductive and grounded panel, which is simultaneously the boundary to the higher protection zone containing the equipment to be protected. It is recommended to place quarter-wave (QW) or gas discharge tube (GDT) protective devices as follows: at the line entrance into the structure or alternatively close to the equipment to be protected.

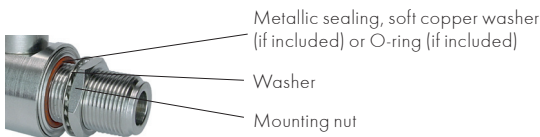

Bulkhead mounting nut torque	Nut size, WAF mm (in)	Torque, Nm (lb-ft)
(WAF: Width Across Flats) Number of mountings: max. 5 cycles	≤ 13 (1/2")	3 to 5 (2.2 to 3.7)
	16 (5/8")	10 to 15 (7.4 to 11.1)
	19 to 25 (3/4" to 1")	15 to 20 (11.1 to 14.8)
	≥ 30 (1 1/8")	30 to 40 (22.1 to 25.8)
Screw mounting	M6	5 to 8 (3.7 to 5.9)
	M8	15 to 20 (11.1 to 14.8)



Preferred installation view to the unprotected side

Protectors without GDT, Series 3400, 3407

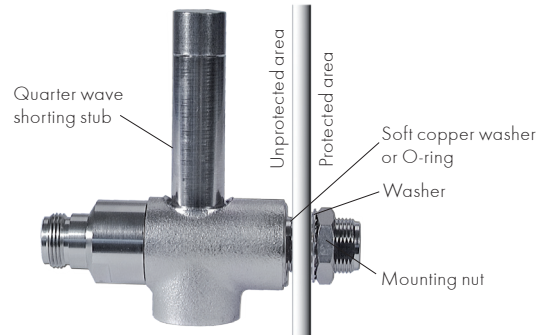

Well conducting and grounded bulkhead

Protectors with GDT Series 3401, 3402, 3403, 3404, 3405, 3406, 3408, 3409, 3410

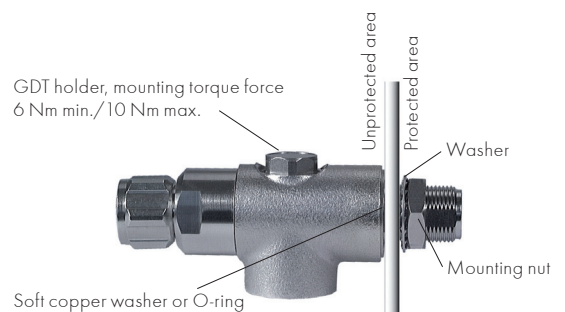

Well conducting and grounded bulkhead

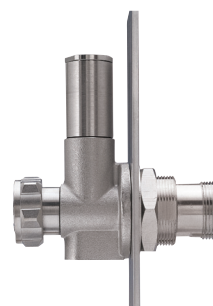

Well grounded panel

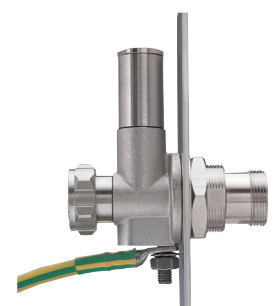

Additional grounding measures are necessary if the panel is poorly grounded

These variants avoid any surge currents, which are down conducted by the protector, to flow into and inside of the protected area where they could induce secondary surge signals.

2. Alternative installation possibilities

The protectors can be installed to the equipotential bonding bar (EBB).

If this is not possible, the protectors should be connected to the bonding facility by a sufficiently sized grounding cable (AWG 6/16 mm² min.) as short distant as possible (0.5 m max.).

The following shows the most common variants:

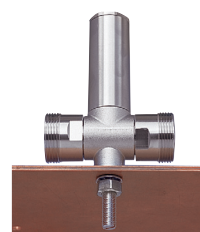

Via screw to EBB

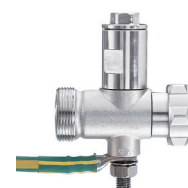

Via screw and grounding cable to EBB



Via grounding lug and cable to EBB

3. Further general recommendations and hints

- The protector should be grounded directly, if possible (not via the connected cable screen), to keep the ground connection as short as possible.
- Make sure the contact transitions are clean and smooth when installing. This is also important for waterproof bulkhead installations.
- Waterproof installations require suitable IEC/MIL conform counter connectors (male connectors include sealing ring), which must be properly tightened.
- With GDT protectors of series 3401, 3402 and 3408 (normally delivered without GDT) select and insert the suitable GDT according to RF power.
- Select the GDT with the lowest suitable static sparkover voltage to achieve best protection. Generally the minimum value of the static sparkover voltage must not be lower than 1.5 times the peak voltage $\hat{u} = \sqrt{2}PZ \cdot (1 + \Gamma) + U_{DC_SUP}$ (RF and DC supply voltage) on the line.
- Recommended GDT holder torque force:
min. 6 Nm (4.4 lb-ft); max. 10 Nm (7.4 lb-ft)
- Series 3403, 3404, 3405, 3406, 3409 and 3410 products are shipped with GDT included.
- When connecting cables, the protector has to be counter-held by a spanner across existing flats on the protector head.
- Coupling nut torque forces according to IEC standard or manufacturer detail specifications.
7/16: min. 25 Nm (18.4 lb-ft); max. 30 Nm (22.1 lb-ft)
N: min. 0.68 Nm (6.0 lb-in); max. 1.13 Nm (10.0 lb-in)
- If exposed to harsh environment, especially icy conditions or polluted atmosphere, the protector should be covered with a self-vulcanising tape or a cold shrink tube.
- When installing and grounding protectors the electrochemical potential between different metallic contacts should not exceed 250 mV (acc. to MIL-F-14072). If exceeding, the contact area must be taped, coated or sealed in order to minimize electrochemical corrosion.
- Especially protectors made of copper alloy base material and trimetal plating mated with connectors made of aluminium or vice versa must be taped to improve long-term durability.
- Any liability or responsibility for the result of improper installation is disclaimed.
- Maximum continuous operating voltage U_c :
0 V for protectors without GDT and quarter-wave/filter high-pass protector devices
48 V for protectors with inserted GDT, except for fine protector types series 3403, see specific type label



WARNING

Disconnect or switch off in-line equipment when installing, checking, disconnecting and connecting EMP protectors. This includes also the exchange of gas discharge tubes. Keep back from such activities during thunderstorms.

Be aware that only a complete protection system according to IEC 62305 can protect your equipment and personnel against the impact of lightning.

This includes an external lightning protection system with air terminal, down conductor and grounding system and bonding of all incoming and outgoing lines (e.g. protectors for mains, data and telephone lines) - not RF lines only.

With gas discharge tube protectors make sure that the GDT has been properly installed before putting the equipment into operation.

Part name 部件名称	Toxic or hazardous substances and elements 有毒有害物质或元素					
	Lead (Pb) 铅	Mercury (Hg) 汞	Cadmium (Cd) 镉	Hexavalent chromium (Cr VI) 六价铬	Polybrominated biphenyls (PBB) 多溴联苯	Polybrominated diphenyl ethers (PBDE except decabromodiphenyl oxide) 多溴二苯醚 (不包括十溴二苯醚)
Metal and metallic parts 金属和金属成分	X	O	O	O	O	O
Plastics and polymers 塑胶和聚合物	O	O	O	O	O	O

O: Indicates that this toxic or hazardous substance contained in all of the homogeneous materials for this part is below the limit requirement in SJ/T11363-2006.
X: Indicates that this toxic or hazardous substance contained in at least one of the homogeneous materials used for this part is above the limit requirement in SJ/T11363-2006.
(Enterprises may further provide in this box technical explanation for marking "X" based on their actual conditions.)
O: 表示该有毒有害物质在该部件所有均质材料中的含量均在SJ/T11363-2006标准规定的限量要求以下。
X: 表示该有毒有害物质至少在该部件的某一均质材料中的含量超出SJ/T11363-2006标准规定的限量要求。(企业可在此处,根据实际情况对上表中打"X"的技术原因进行进一步说明。)